



V. Bech
Tools

DIN TEKNOLOGIPARTNER
FOR INNOVATIV SPÅNTAGNING

VORES HISTORIE

1968

J. Madsen træder ind. Firmaet kaldes V. Bech & Co. I/S

1986

H.D. Madsen træder ind i firmaet

1967

Vagn Bech Petersen etablerer firmaet

1975

Firmaet flytter fra Århus C til Brabrand

1979

Vagn Bech Petersen købes ud af J. Madsen

2015

Sliberiet udvides

2016

ANCA TX Celle 1 installeres

2004

CNC-Sliberi etableres ANCA RX7 og TX7 installeres

2021

V. Bech & Co A/S sælges til Thomas Nielsen

1990

Firmaet omdannes
til aktieselskab
V. Bech & Co. A/S

1995

Grunden i
Sabro købes

2000

Firmaet flytter
fra Brabrand
til Sabro

1991

Indhentning af
egen agenturer
indledes

1992

25-års jubilæum
(skæredatatalog)

2022

H.D. Madsen
træder ud af
V. Bech Tools A/S

2022

Thomas Bangsmann
træder ind som CEO
i V. Bech Tools A/S

2023

V. Bech Tools A/S
køber LKS Tools

2022

V. Bech & Co A/S
skifter navn til
V. Bech Tools A/S

2022

ANCA TX Celle 2
installeres

VORES SALES TEAM

Thomas Bangsmann
Henrik Eskildsen
Jørgen Jensen
Lars Noesgaard
Jacob Thomsen
Michael Bang Pedersen





*Vi leverer skærende værktøjer
til den spåntagende industri*

VORES EGENPRODUKTION OG RE-NEW AF HM VÆRKTØJER

- 4 stk. High-End ANCA slibemaskiner med robot
- Zoller genius 3 målemaskine
- Zoller PomskpGo – for måling af edge præparation
- Bredt program af standard HM performances End Mills VB serie – Materialer stål, Støbegods og rustfri
- Bred erfaring i fremstilling af special HM værktøjer
- Re-new service af HM værktøjer – også "fremmed" værktøjer

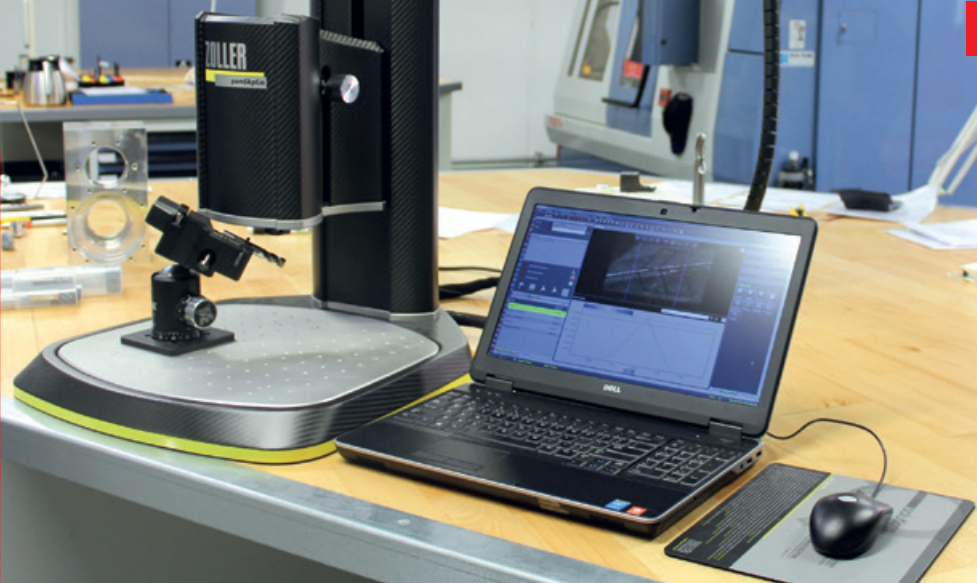
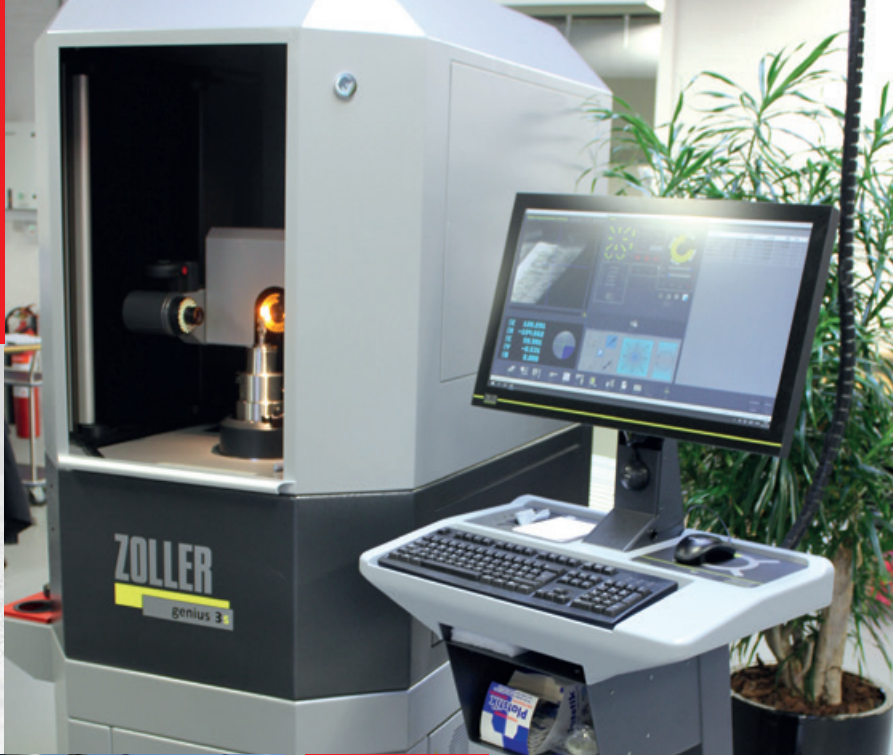

V. BECH TOOLS TRINBOR VB110

- Hurtig levering 8 arbejdes dage fra bestilling
- Materiale Stål (P) Støbegods (K) Aluminium (N)
- Ny VB5 belægning for Stål og Støbegods
- Ubelagt for Aluminium
- Hurtig konstruktion, ud fra Excel skema
- Tol. trinlænde +- 0,05
- Vinkel 140° +- 0,1°

VB110 V. Bech Tools

Excel blad	Skafte Ø HA	min/max Dia.	Trinlængde max	Min. Bestilling
M3 skafte Ø6	Ø6 h6	Ø2,5/Ø6 m7	9mm	2 stk.
M4 skafte Ø6	Ø6 h6	Ø3,3/Ø6 m7	12mm	2 stk.
M5 skafte Ø6	Ø6 h6	Ø4,2/Ø6 m7	14mm	2 stk.
M6 skafte Ø8	Ø8 h6	Ø5/Ø8 m7	19mm	2 stk.
M8 skafte Ø10	Ø10 h6	6,8/Ø10 m7	23mm	2 stk.
M10 skafte Ø12	Ø12 h6	Ø8,5/Ø12 m7	27mm	2 stk.
M12 skafte Ø14	Ø14 h6	Ø10,2/Ø14 m7	32mm	2 stk.
M16 skafte Ø18	Ø18 h6	14/Ø18 m7	40mm	2 stk.



V. BECH TOOLS PARTNER

ARNO WERKZEUGE – OSTFILDERN- DE



- High Performance ISO dreje vendeskær
- Alle former for indvendig, udvendig og profil løsninger stik
- Langdreje løsninger
- Roterende værktøjer



V. BECH TOOLS PARTNER
PALBIT – PORTUGAL



- Producent af hårdmetal
- High Performance ISO dreje vendeskær
- Roterende værktøjer
- High End vendeskær fræseprogram

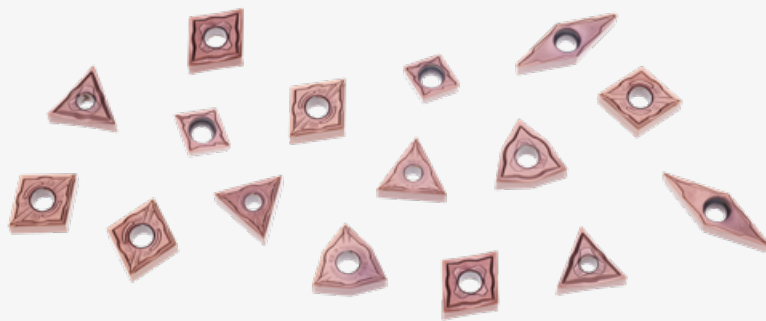
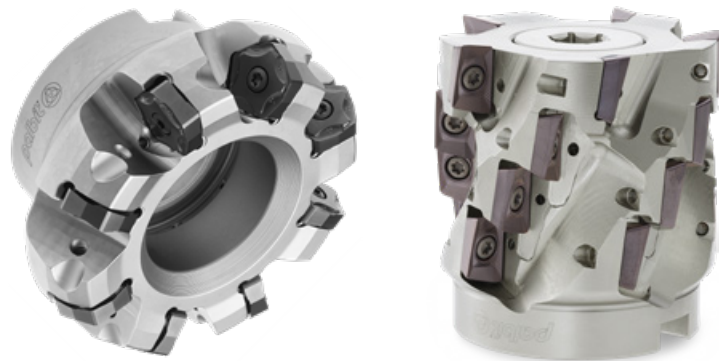

V. BECH TOOLS PARTNER

MK TOOLS – HAUZENBERG – DE



- Førende producent af standard HM bor
- Førende producent af HM special bor (CoreDrill – CavityDrill)

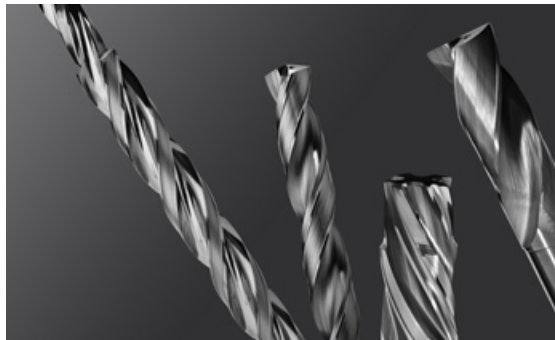

V. BECH TOOLS PARTNER

VERGNANO – IT



- Førende producent af standard tappe
- Bredt program i HSS/HM tappe
- High end Performance P serie



V. BECH TOOLS PARTNER

VAN HOORN CARBIDE – NL

VAN HOORN  **CARBIDE**

- Førende producent af High End HM End Mills
- Die & Mold End Mills
- Aluminiums End Mills



V. BECH TOOLS PARTNER

HUFSCHMIED – BOBINGEN-DE

HUFSCHMIED
ZERSPANUNGSSYSTEME

- High End producent af HM End Mills
- Bearbejdning alle kunststof materialer
- Grafit bearbejdning
- Kobber bearbejdning
- Die & Mold op til 72Hrc
- Aluminiums End Mills

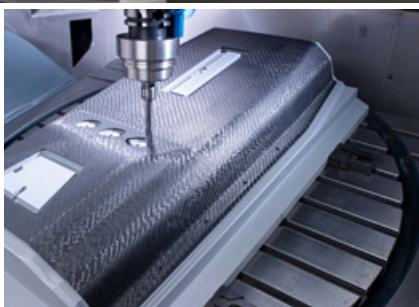

V. BECH TOOLS PARTNER

DIATool – RHEINFELDEN-DE



- High End producent Rivaler
- Rival fra $\text{\O}5,6$ til $\text{\O}205$
- Special rivaler
- Alle materialer



V. BECH TOOLS PARTNER

BOTEK – RIEDERICH-DE

botek

- Førende producent dybdehuls bor
- Ø0,5 til Ø750
- Op til 2500mm dybde
- HM og vendeskærs bor

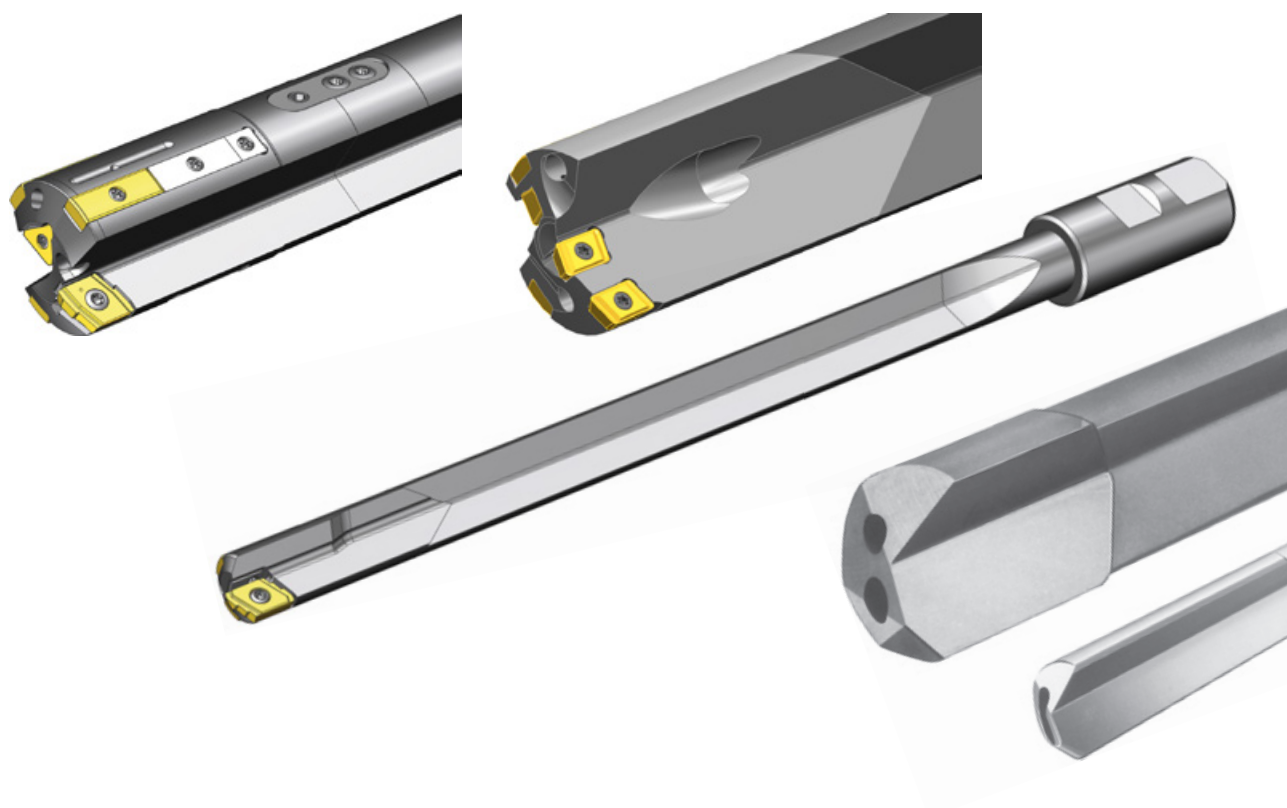

V. BECH TOOLS PARTNER

HACHENBACH – EHRINGSHAUSEN-DE



- Producent af hårdmetal End Mills
- Bredt program Alu bearbejdning



V. BECH TOOLS PARTNER

MIMATIC – BETZIGAU-DE



- Producent af high End roterende værktøjer
- Roterende værktøjer for Mazak
- Roterende værktøjer for DMG MORI
- Roterende værktøjer for Okuma
- Roterende værktøjer for HAAS
- Special løsninger
- Reparation af alle roterende værktøjer
- Også "fremmede" mærker
- Roterende værktøjer til alle maskinfabrikater

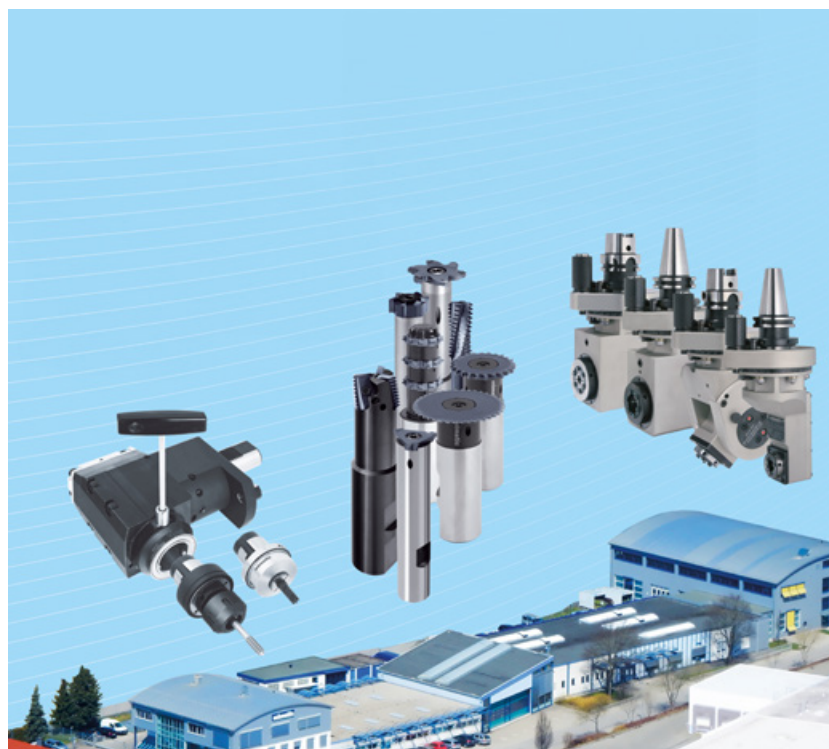
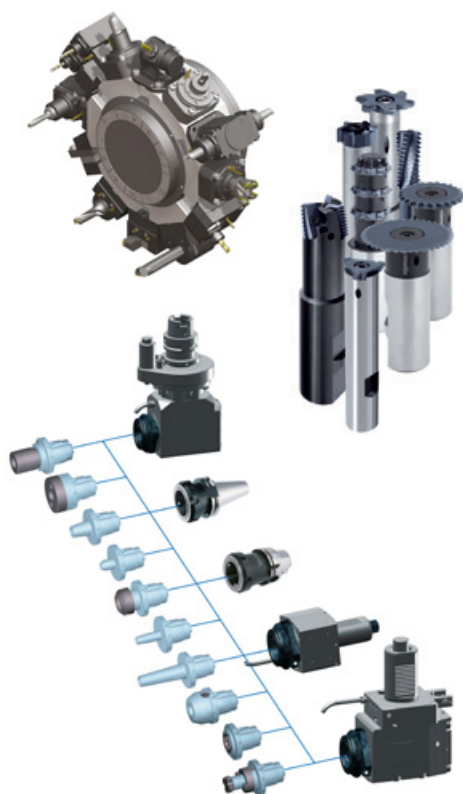

V. BECH TOOLS PARTNER

TELA – HORB A.N. AHLDORF-DE

TELA

- Producent af PKD værktøjer
- ISO vendeskær special værktøjer
- Opbore værktøjer med vendeskær



V. BECH TOOLS PARTNER

ELBO CONTROLLI - IT



- Producent af High End forindstillings apparater
- Fundament naturgranit
- Software gratis opdatering
- Alle optioner er inkl. i prisen
- Måling op til Ø800mm Længde 1000mm
- Industri 4.0



V. BECH TOOLS

ØVRIGE SAMARBEJDSPARTNERE

ata KarnaschiBOWERSC.P.T.
Präzision WerkzeugeERIX
TOOL ABKEMPF
SONDERWERKZEUGE IN PRÄZISIONKINTEKKoreaTechnicsKROMIrineck
WerkzeugtechnikRUKOWERKÖYes YESTOOL Co., Ltd.



*Vi fremstiller specialværktøjer
til bearbejdning i metal,
med fokus på eksotiske materialer*







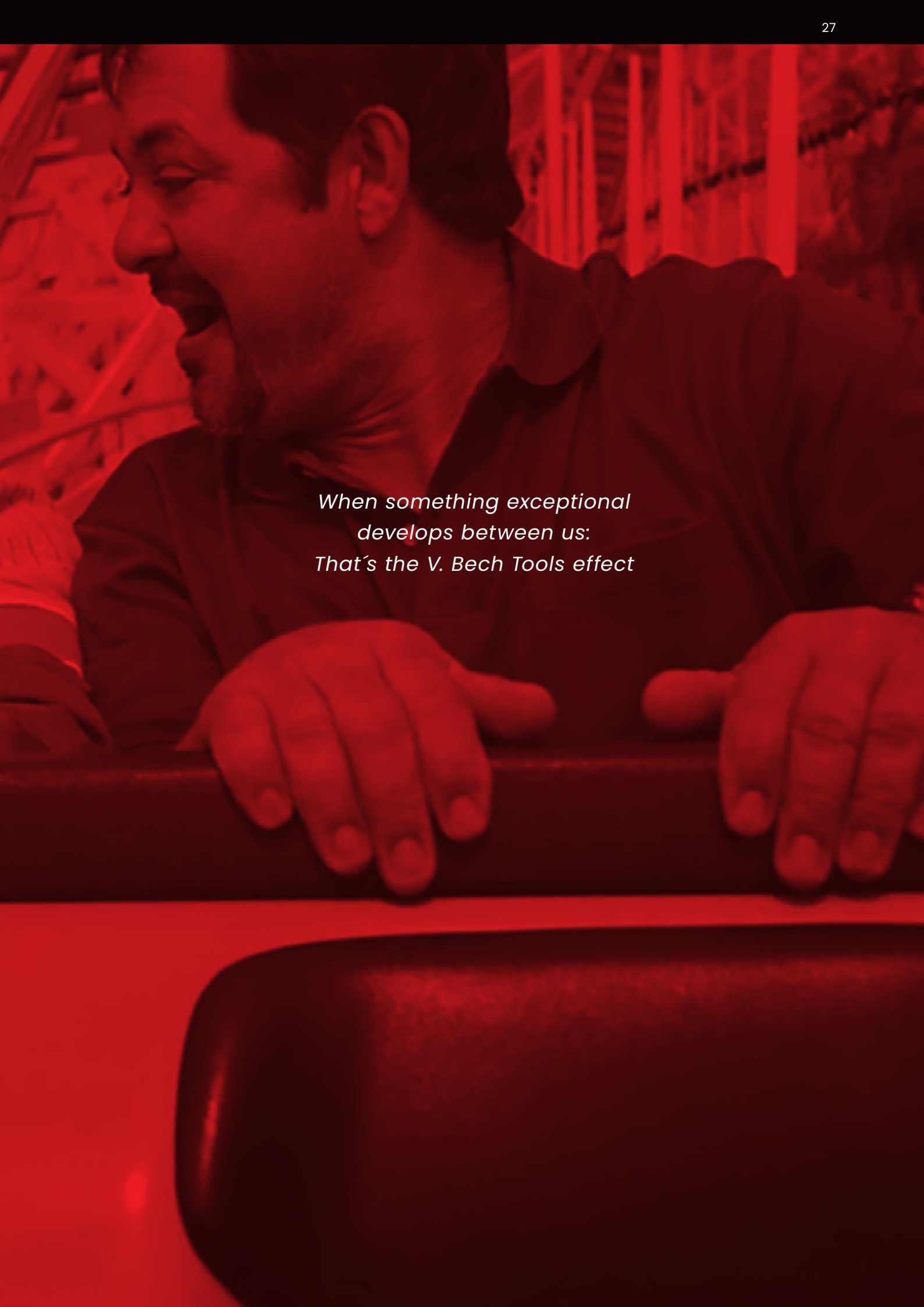

*When something exceptional
develops between us:
That's the V. Bech Tools effect*



V. Bech Tools

V. BECH TOOLS A/S

DAMVEJ 3

DK-8471 SABRO

TLF.: +45 87 48 66 66

E-MAIL: SALES@VBECH.DK

WEB: WWW.VBECH.DK